

ADHESIVO 3M DOBLE CARA

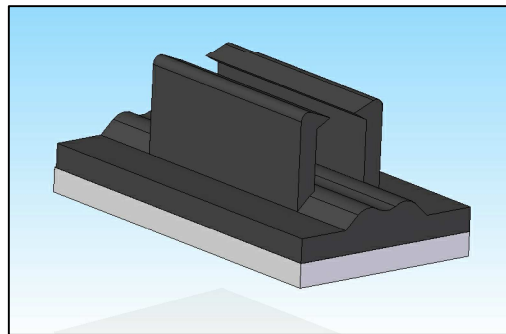

REF.	A	B	C	D	E	EMBALAJE PACKAGING	Pedido Min. Min. Qty. Order
FHMI-025	8.5	2.5	2.7	5.0	15.2	500	1000
FHMI-036	9.0	3.6	4.0	6.5	16.0	500	1000

Revision Revisión	Resp.	Date Fecha	Description Descripción
			Modifications Modificaciones

Project Proyecto	WIRE MOUNT FIJACION CABLEADO			Material	PA 66 (UL 94V-2)		This drawing contains confidential information. Not allowed its reproduction total or partial <i>Este plano contiene información confidencial.            Queda prohibida su distribución total o parcial</i> All dimensions in metric system <i>Unidades en sistema métrico</i>
Part name Denominación	FIXING CLAMP FIJACION ADHESIVA			Color	BLACK / NEGRO		
Reference Referencia	FHMI			Finish Acabado			
Drawn Dibujado Checked Comprobado	Name Nombre	Signature Firma	Date Fecha	Tolerances unless noted Tolerancias salvo indicación	Angles Ángulos	Version Versión	Version Versión
	G.Lamothe		11/10/16	Dimensions Cotas	± 0.2	Sheet size Tamaño página	DIN A4
					± 0.5	Sheet number Hoja número	

