

REFS.	Grueso placa P.C.B. thickness		A	B	C	D	E	F
GCILA-38-1	1,6	38,3	20	9,2	6,4	3,4	3,2	
	1,7							
GCILA-38-2	2	38,4	20	9,2	6,4	3,4	3,2	
GCILA-40-1	1,6	40	20	8	6	3	3	
GCILA-51-1	1,6	51	38,2	9,2	6,4	3,4	3,2	
	1,7							
GCILA-81-1	1,6	81	60	8	6	3	3	
	1,8							
GCILA-81-2	1,8	81	60	8	6	3	3	
	2,1							
GCILA-81-3	1,8	81	60	8	6	3	3	
GCILA-81-4	2,5	81	60	8	6	3	3	
GCILA-91-1	1,6	91,5	71	8	6	3	3	
	1,8							
GCILA-91-2	1,8	91,5	71	8	6	3	3	
	2,1							

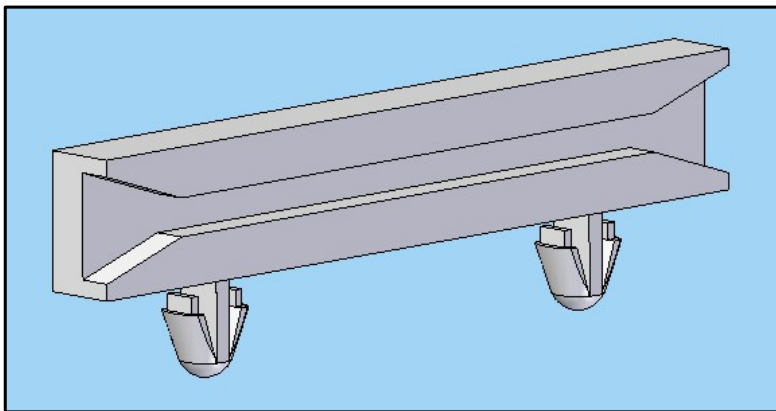

Revision	Resp.	Date	Description
Revisión		Fecha	Descripción
Revision	Resp.	Date	Description
Revisión		Fecha	Descripción

Modifications  
Modificaciones

Project	P.C.B. Card guide			Material	PA66 V2		
Proyecto	Guia para placas de circuito impreso				Color	Natural	
Part name	HORIZONTAL P.C.B. CARD GUIDE			Finish		Flat	
Denominación	GUIA HORIZONTAL PARA PLACAS DE CIRCUITO IMPRESO				Acabado	Liso	
Reference	GCILA			Tolerances unless noted		Version	Version
Referencia	Name	Signature	Date		Dimensions		
Drawn	A.Amores		4/10/2010	Cotas	Tamaño página	Tamaño página	Tamaño página
Checked				± 0.2	Ángulos	Ángulos	Ángulos
Comprobado				± 0.5	Sheet number	Sheet number	Sheet number
					Hoja número	Hoja número	Hoja número



**Electronics  
Technologies  
Plastics**

This drawing contains confidential information.  
Not allowed its reproduction total or partial.  
Este plano contiene información confidencial.  
Queda prohibida su distribución total o parcial.  
All dimensions in metric system  
Unidades en sistema métrico