

REF	Ø AGUJERO	GRUESO PANEL	A	B	C	D	EMBALAJE
	Ø HOLE	PANEL THICKNESS					PACKING
PRK-1	8.0	1.0-2.5	20.8	11.8	19.8	6.4	1.000
PRK-10	8.0	1.0-2.5	23.8	10.0	22.0	5.0	1.000
PRK-11	10.0	1.0-3.5	31.5	13.6	28.5	7.8	1.000
PRK-12	8.0	1.0-3.0	20.0	20.8	18.0	15.0	1.000
PRK-13	8.0	0.8-1.0	20.0	24.3	18.0	18.0	1.000
PRK-14	8.0	0.8-2.0	19.5	10.5	18.7	5.0	1.000
PRK-16	10.0	1.0-3.5	29.4	23.0	26.5	15.0	1.000
PRK-19	4.0	0.8	20.0	9.1	18.0	6.0	1.000
PRK-2	8.0	1.0-2.5	20.0	15.4	18.0	10.0	1.000
PRK-20	5.0	0.8	20.0	8.4	18.0	5.2	1.000
PRK-21	8.0	0.8-2.0	20.0	25.6	19.3	20.5	1.000
PRK-22	8.0	0.8-1.2	19.2	12.1	17.2	7.9	1.000
PRK-24	8.0	0.8-2.0	23.0	13.3	21.0	8.0	1.000
PRK-25	8.0	0.8-2.0	24.0	15.8	20.0	10.5	1.000
PRK-26	8.0	1.0-3.0	22.0	10.5	21.0	3.5	1.000
PRK-27	8.0	1.0-3.0	26.7	21.0	24.8	16.0	1.000
PRK-28	8.0	0.8-2.0	20.0	13.5	18.0	10.0	1.000
PRK-3	8.0	1.0-2.5	23.7	19.2	19.5	13.7	1.000
PRK-31	10.0	0.8-2.0	27.0	12.0	26.0	6.9	1.000
PRK-34	10.0	0.8-2.0	41.2	21.6	40.0	14.0	1.000
PRK-35	6.0	1.0-2.5	14.0	10.6	12.7	5.8	1.000
PRK-36	8.0	1.0-3.0	22.0	10.5	20.0	3.5	1.000
PRK-4	8.0	1.0-2.5	25.0	12.5	23.5	6.5	1.000
PRK-41	8.0	1.0-2.5	20.8	12.6	19.8	7.2	1.000
PRK-43	5.0	1.0-2.5	12.0	10.0	10.5	5.8	1.000
PRK-44	8.0	1.0-2.5	20.8	11.8	19.8	6.9	1.000
PRK-5	8.0	1.0-2.5	30.0	18.8	27.7	12.8	1.000
PRK-6	10.0	1.0-3.5	28.5	14.0	26.5	8.2	1.000
PRK-7	5.0	1.0-2.0	12.7	8.5	12.0	4.4	1.000
PRK-8	5.0	1.0-2.0	15.7	8.5	15.0	4.4	1.000
PRK-9	8.0	1.0-2.0	20.0	7.0	18.6	4.0	1.000

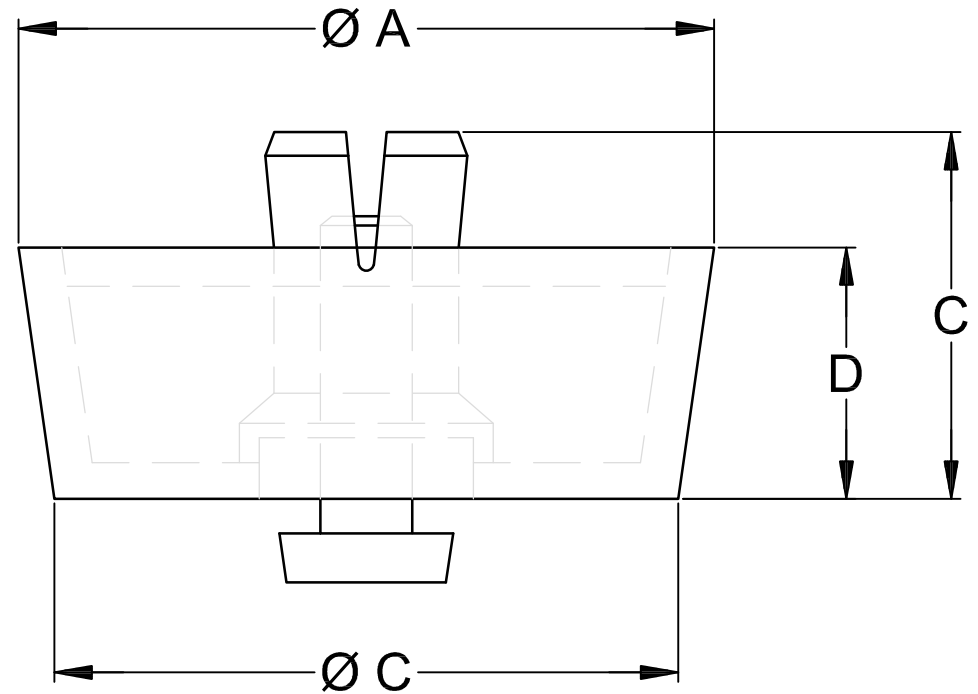

TOL. GEN. DIN 7168	>0.5 a 6	>6 a 30	>30 a 120	>120 a 315	>315 a 1000	>1000 a 2000
FINO	± 0.05	± 0.1	± 0.15	± 0.2	± 0.3	± 0.5
MEDIO	± 0.1	± 0.2	± 0.3	± 0.5	± 0.8	± 1.2
BASTO	± 0.2	± 0.5	± 0.8	± 1.2	± 2	± 3

TOLERANCIA GENERAL: MEDIO
GENERAL TOLERANCE: MEDIO

Revision	Resp.	Date	Description
Revisión	Responsable	Fecha	Descripción

Modifications / Modificaciones

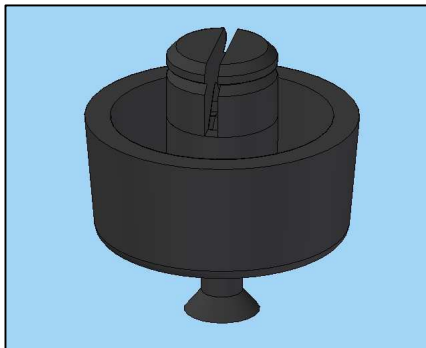

Project / Proyecto	Stability and support / Soporte y estabilidad			Material	PE / TPR		This drawing contains confidential information. / Not allowed its reproduction total or partial. / Este plano contiene información confidencial. / Queda prohibida su distribución total o parcial. / All dimensions in metric system / Unidades en sistema métrico
Part name / Denominación	RIVET HELD FEET / PIE FIJACION REMACHE			Color	Black / Negro		
Reference / Referencia	PRK			Finish / Acabado	Flat / Liso		
Drawn / Dibujado	Name / Nombre	Signature / Firma	Date / Fecha	Tolerances unless noted / Tolerancias salvo indicación	Version / Versión	Version / Versión	
Checked / Comprobado	G. Lamothe		02/10/17	Dimensions / Cotas	Sheet size / Tamaño página	Sheet number / Hoja número	DIN A4
				± 0.2	± 0.5		

