

| | D | A | H | C | L | B | |
|--------|------|-------|-------|-------|-------|-------|-----|
| RRS-95 | 3.68 | 3.3 | 15.08 | 5.21 | 7.75 | 3.2 | |
| RRS-48 | 3.99 | 8 | 9.93 | 5.28 | 12.4 | 2.9 | |
| RRS-49 | 4.06 | 11.4 | 8.73 | 5.08 | 17.27 | 4.1 | |
| RRS-33 | | 12.8 | 9.52 | | 18.67 | | |
| RRS-51 | 4.19 | 1.7 | 8.73 | 5.13 | 8.26 | 3.5 | |
| RRS-50 | | 3.4 | | | 7.75 | | |
| RRS-27 | | 27 | 9.52 | | 33 | 4.5 | |
| RRS-53 | 4.45 | 6.4 | 8.73 | 5.69 | 12.45 | 4.4 | |
| RRS-28 | | 22.2 | | | 28.32 | | |
| RRS-55 | 4.57 | 14.1 | 9.52 | 5.71 | 19.56 | 3.7 | |
| RRS-52 | | 14.1 | | 5.72 | 19.81 | 3.9 | |
| RRS-37 | | 16.2 | | 22.22 | 5.59 | 22.23 | 4.6 |
| RRS-34 | | 16.2 | | 19.05 | | 22.23 | |
| RRS-76 | 5 | 3.3 | 19.01 | 6.05 | 10.13 | 3.8 | |
| RRS-58 | 5.08 | 3.1 | 11.90 | 8.23 | 9.12 | 3.9 | |
| RRS-60 | | 4 | | 5.79 | | | |
| RRS-61 | 5.16 | 9.5 | 8.73 | 5.99 | 14.02 | 3.5 | |
| RRS-31 | 5.84 | 12.8 | 9.93 | 7.49 | 27.61 | 5.3 | |
| RRS-62 | | 43.9 | | | 51.05 | | |
| RRS-83 | 6.15 | 1.6 | 12.7 | 7.11 | 7.42 | 4.3 | |
| RRS-84 | | 2.5 | | | 8.23 | | |
| RRS-85 | | 3.2 | | | 9.17 | | |
| RRS-86 | | 4 | | 9.93 | 7.14 | 10.82 | 4.5 |
| RRS-87 | | 4.8 | | 7.06 | | | |
| RRS-88 | | 5.6 | | 7.04 | 11.56 | | |
| RRS-89 | | 6.4 | | 7.19 | 12.37 | | |
| RRS-71 | | 6.4 | | 15.08 | 7.62 | 12.62 | 4.8 |
| RRS-63 | | 7 | | 11.51 | 7.49 | 12.83 | |
| RRS-90 | | 7.1 | | 12.7 | 7.11 | 13.03 | 4.5 |
| RRS-64 | 7.6 | 11.51 | 7.49 | 13.6 | 4.8 | | |
| RRS-91 | 8 | 12.7 | 7.14 | 13.2 | 3.86 | | |

| | D | A | H | C | L | B |
|--------|------|-----|------|-------|-------|-----|
| RRS-36 | 2.29 | 1.7 | 4.75 | 2.54 | 4.55 | 1.9 |
| RRS-41 | 2.26 | 3.1 | 7.94 | 3.68 | 6.25 | 2.2 |
| RRS-35 | | 3.2 | | 2.8 | 5.96 | 1.8 |
| RRS-59 | 2.29 | 3.7 | 4.75 | 2.66 | 6.48 | 1.7 |
| RRS-38 | 2.36 | 1.6 | 7.14 | 2.67 | 4.47 | 2 |
| RRS-40 | | 2.4 | | | 5.23 | |
| RRS-39 | | 2.9 | 6.35 | 3.68 | 6.10 | 2.2 |
| RRS-56 | 2.41 | 8 | 3.56 | 3.43 | 11.43 | 1.9 |
| RRS-75 | 2.84 | 14 | 6.35 | 3.68 | 18.92 | 3.4 |
| RRS-47 | 2.92 | 3.1 | 5.16 | | 7.24 | 3.2 |
| RRS-44 | | 3.4 | | 7.75 | 3.4 | |
| RRS-43 | | 4 | | 7.70 | | |
| RRS-45 | | 6 | | 3.48 | 8.51 | 1.8 |
| RRS-32 | | 6 | | 3.68 | 8.66 | 1.7 |
| RRS-46 | | 6.4 | | | 10.03 | 3.4 |
| RRS-77 | 3.30 | 8.1 | 5.95 | 11.10 | 2.1 | |
| RRS-42 | | 4.8 | 5.16 | 4.57 | 8.13 | 2.3 |
| RRS-29 | | 5.3 | | 4.55 | 8.69 | |
| RRS-54 | 6.48 | 5 | 8.73 | 7.49 | 10.54 | 4.7 |

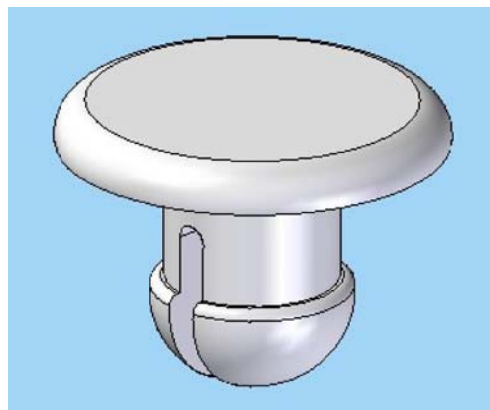
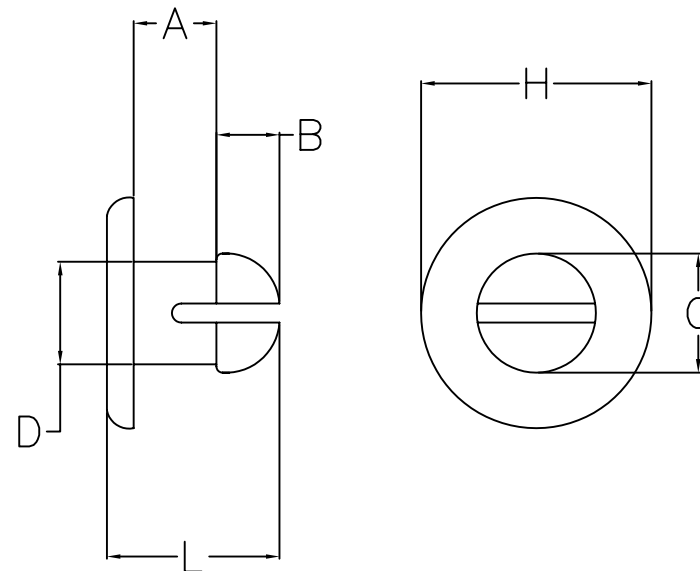

| Revision | Resp. | Date | Description |
|----------|-------|-------|-------------|
| Revisión | | Fecha | Descripción |
| Revision | Resp. | Date | Description |
| Revisión | | Fecha | Descripción |

Modifications
Modificaciones

This drawing contains confidential information.
Not allowed its reproduction total or partial
*Este plano contiene información confidencial.
Queda prohibida su distribución total o parcial*
All dimensions in metric system
Unidades en sistema métrico

| TOL.GEN.DIN 7168 | >0.5 a 6 | >6 a 30 | >30 a 120 | >120 a 315 | >315 a 1000 | >1000 a 2000 |
|------------------|----------------|---------------|-----------------|------------------|-------------------|--------------------|
| FIND | ± 0.05 | ± 0.1 | ± 0.15 | ± 0.2 | ± 0.3 | ± 0.5 |
| MEDIO | ± 0.1 | ± 0.2 | ± 0.3 | ± 0.5 | ± 0.8 | ± 1.2 |
| BASTO | ± 0.2 | ± 0.5 | ± 0.8 | ± 1.2 | ± 2 | ± 3 |

TOLERANCIA GENERAL:
GENERAL TOLERANCE: MEDIO

| Project Proyecto | Fastening Sujección | | | Material | PA66 V2 | This drawing contains confidential information. Not allowed its reproduction total or partial <i>Este plano contiene información confidencial. Queda prohibida su distribución total o parcial</i> All dimensions in metric system <i>Unidades en sistema métrico</i> |
|-------------------------|--------------------------------|--------------------|---------------|---|--------------------|---|
| Part name | SNAP LOCK RIVET | | | | | |
| Denominación | REMACHE COLOCACION INSTANTANEA | | | Finish Acabado | Flat Liso | |
| Reference Referencia | RRS | | | Tolerances unless noted Tolerancias salvo indicación | Version Versión | Version Versión |
| | Name Nombre | Signature Firma | Date Fecha | Dimensions Cotas | Angles Ángulos | Sheet size DIN A4 |
| | A.Amores | | 13/10/10 | ± 0.2 | ± 0.5 | Sheet number Hoja número |

