

AGUJERO CHASIS
CHASSIS HOLE

AGUJERO PLACA
P.C.B. HOLE

REF	Ø AGUJERO PLACA	Ø AGUJERO CHASIS	GRUESO PLACA	GRUESO CHASIS	A	B	C	PZAS CAJA
	Ø P.C.B. HOLE	Ø CHASSIS. HOLE	P.C.B. THICKNESS	CHASSIS THICKNESS				BOX QTY
SCAB3L-035	4	5,5	1,2-1,7	2,8-1,6	3,5	10	10	1.000
SCAB3L-060	4	5,5	1,2-1,7	1-1,7	6	10	10	1.000
SCAB3L-095	3,2	4,8	1,6	0,5-1	9,5	9,5	8,7	1.000
SCAB3L-100	4	5,5	1,2-1,7	1-1,7	10	10	10	1.000
SCAB3L-127	4	5,5	1,2-1,7	1-1,7	12,7	10	10	1.000
SCAB3L-127-P	3,2	4,8	1,6	0,5-1	12,7	9,5	8,7	1.000
SCAB3L-159	3,2	4,8	1,6	1,5-1	15,9	9,5	8,7	1.000
SCAB3L-5-060	4	2	1,2-1,7	0,8-1,8	6	9,7	4,7	1.000

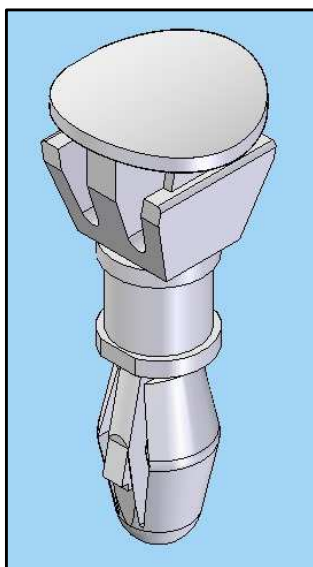

R01	G. Lamothe	17-09-18	Cotas "B" y "C" actualizadas
Revision	Resp.	Date	Description
Revisión		Fecha	Descripción
Modifications Modificaciones			

Project Proyecto	Spacer Separador			Material	PA66 V2			This drawing contains confidential information. Not allowed its reproduction total or partial <i>Este plano contiene información confidencial. Queda prohibida su distribución total o parcial.</i> All dimensions in metric system <i>Unidades en sistema métrico</i>
Part name Denominación	P.C.B. SUPPORT POST SEPARADOR PLACA VERTICAL				Color	Natural		
Reference Referencia	SCAB3L			Finish Acabado	Finish Acabado			
Drawn Dibujado Checked Comprobado	Name Nombre	Signature Firma	Date Fecha	Tolerances unless noted Tolerancias salvo indicación	Angles Ángulos	Version Versión	Version Versión	
	A. Amores		18-10-10	Dimensions Cotas	± 0.2	Sheet size Tamaño página	DIN A4	
				Angles Ángulos	± 0.5	Sheet number Hoja número		

